



## **User Manual – AS5510 Adapterboard**

# **AS5510**

**10-bit Linear Incremental Position Sensor with Digital  
Angle output**

## Table of Contents

1	General Description .....	3
2	Board Description.....	3
3	Pinout .....	4
4	Mounting the AS5510 Adapterboard.....	5
5	Connecting the AS5510-AB .....	7
6	Software example .....	8
7	Schematic and Layout .....	10
8	Ordering Information .....	10
9	Copyright.....	11
10	Disclaimer .....	11
11	Contact Information.....	11

## Revision History

Revision	Date	Owner	Description
1.0	1.09.2009		Initial revision
1.1	28.11.2012		Update
1.2	21.08.2013	AZEN	Template Update, Figure Change

## 1 General Description

The AS5510 is a linear Hall sensor with 10 bit resolution and I<sup>2</sup>C interface. It can measure absolute position of lateral movement of a simple 2-pole magnet. The typical arrangement is shown below in (Figure 1).

Depending on the magnet size, a lateral stroke of 0.5~2mm can be measured with air gaps around 1.0mm. To conserve power, the AS5510 may be switched to a power down state when it is not used.

Figure 1:  
Linear Position Sensor AS5510 + Magnet

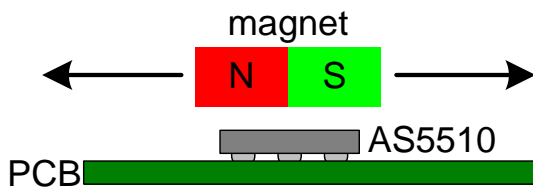

## 2 Board Description

The AS5510 adapter board is a simple circuit allowing to test and evaluate the AS5510 linear encoder quickly without having to build a test fixture or PCB.

The adapterboard must be attached to a microcontroller via the I<sup>2</sup>C bus, and supplied with a voltage of 2.5V ~ 3.6V. A simple 2-pole magnet is placed on the top of the encoder.

Figure 2:  
AS5510 adapter board mounting and dimension

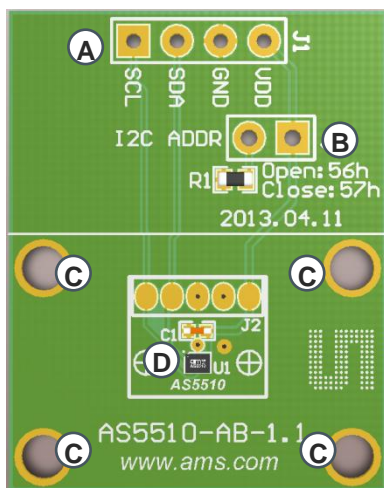

- (A) (A) I2C and Power Supply Connector
- (B) I2C Address selector
  - Open: 56h (default)
  - Closed: 57h
- (C) Mounting holes 4x2.6mm
- (D) AS5510 Linear Position Sensor

### 3 Pinout

The AS5510 is available in a 6-pin Chip Scale Package with a ball pitch of 400µm.

Figure 2:  
Pin Configuration of AS5510 (Top View)

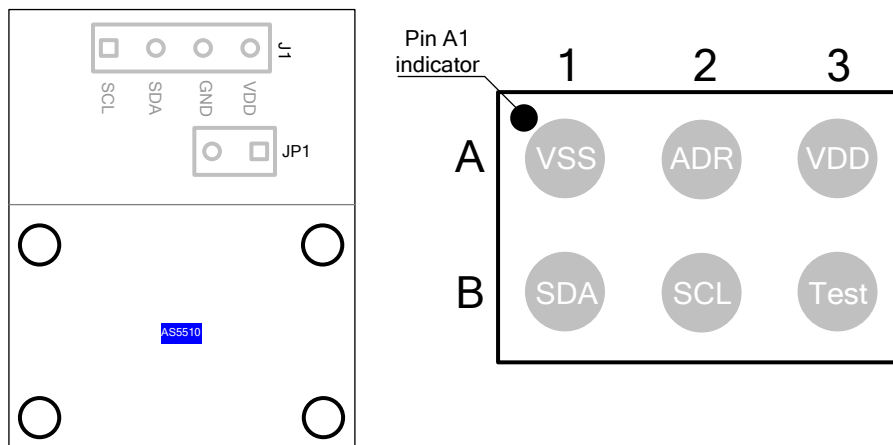

Table 1:  
Pin Description

Pin AB board	Pin AS5510	Symbol	Type	Description
J1: pin 3	A1	VSS	S	Negative supply pin, analog and digital ground.
JP1: pin 2	A2	ADR	DI	I <sup>2</sup> C address selection pin. Pull down by default (56h). Close JP1 for (57h).
J1: pin 4	A3	VDD	S	Positive supply pin, 2.5V ~ 3.6V
J1: pin 2	B1	SDA	DI/DO_OD	I <sup>2</sup> C data I/O, 20mA driving capability
J1: pin 1	B2	SCL	DI	I <sup>2</sup> C clock
n.c.	B3	Test	DIO	Test pin, connected to VSS

DO\_OD ... digital output open drain  
 DI ... digital input  
 DIO ... digital input/output  
 S ... supply pin

#### 4 Mounting the AS5510 Adapterboard

The AS5510-AB can be fixed to an existing mechanical system by its four mounting holes. A simple 2-poles magnet placed over or under the IC can be used.

Figure 3:  
AS5510 adapter board mounting and dimension

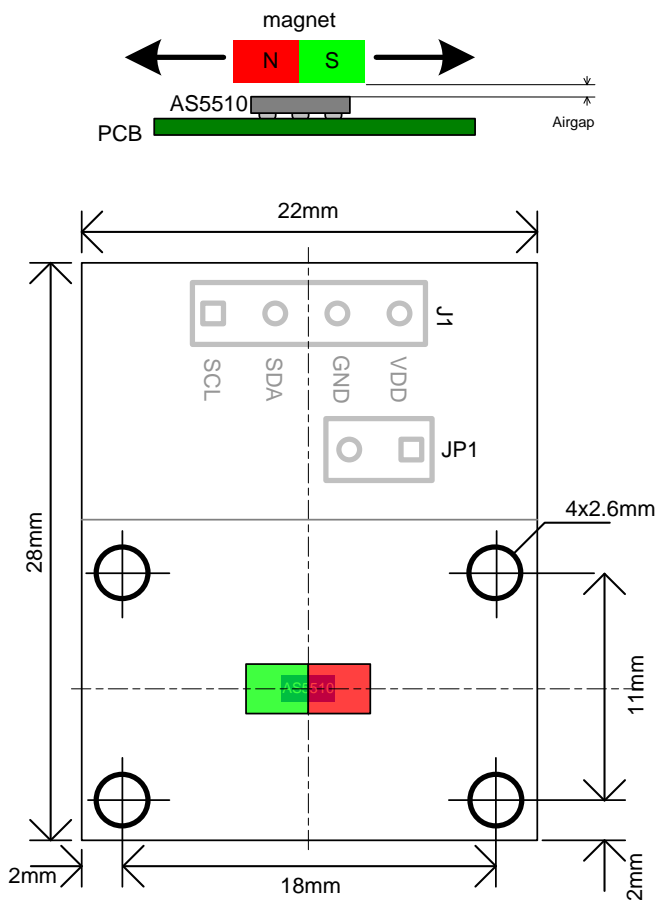

The maximum horizontal travel amplitude depends on the magnet shape and size and magnetic strength (magnet material and airgap).

In order to measure a mechanical movement with a linear response, the magnetic field shape at a fixed airgap must be like on Figure 4:.

The linear range width of the magnetic field between North and South poles determines the maximum travel size of the magnet. The minimum (-Bmax) and maximum (+Bmax) magnetic field values of the linear range must be lower or equal to one of the four sensitivities available on the AS5510 (register 0Bh):

$$\text{Sensitivity} = \pm 50\text{mT}, \pm 25\text{mT}, \pm 18.5\text{mT}, \pm 12.5\text{mT}$$

The 10-bit output register D[9..0] OUTPUT = Field(mT) \* (511/Sensitivity) + 511.

Figure 4:  
Magnet requirement

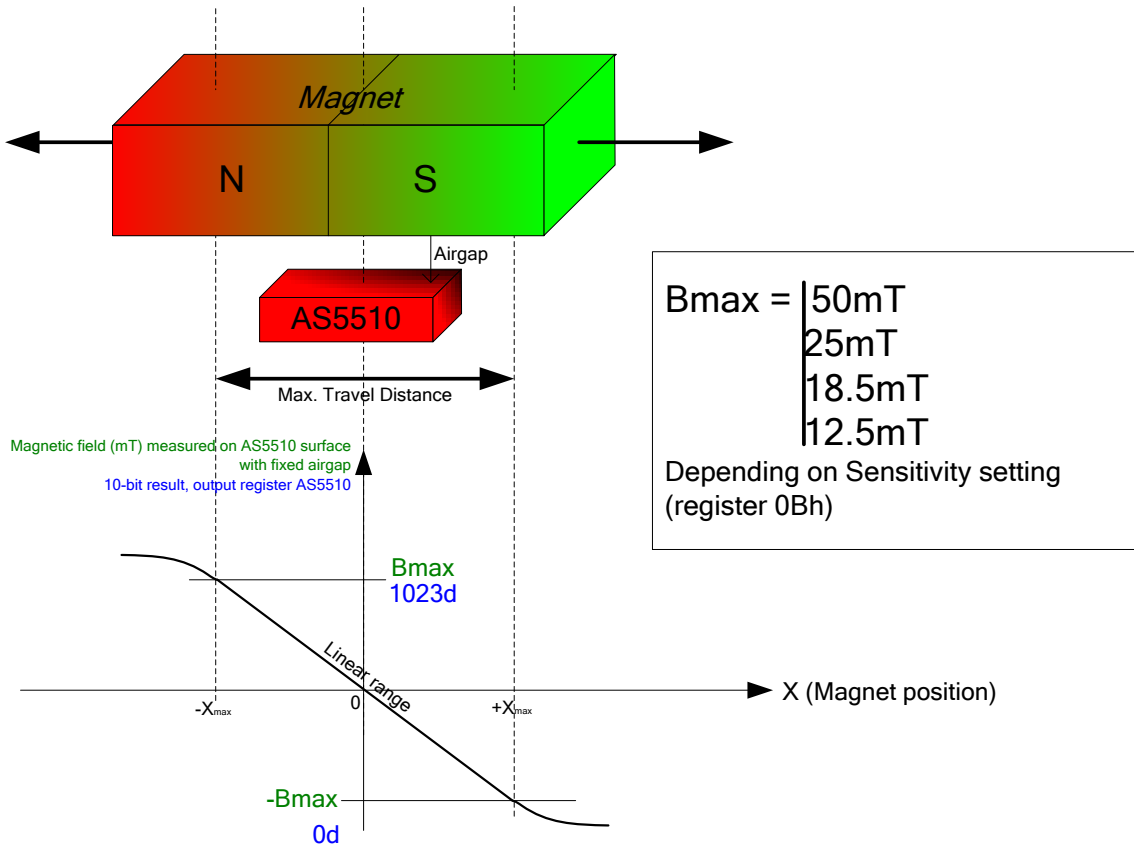

**Example 1:**

This is the ideal case: the linear range of the magnet is  $\pm 25\text{mT}$ , which fits to the  $\pm 25\text{mT}$  sensitivity setting of the AS5510. The resolution of displacement vs. output value is optimal.

Max. Travel Distance  $TD_{\text{max}} = \pm 1\text{mm}$  ( $X_{\text{max}} = 1\text{mm}$ )

Sensitivity =  $\pm 25\text{mT}$  (Register 0Bh  $\leftarrow$  01h)

$B_{\text{max}} = 25\text{mT} \rightarrow X = -1\text{mm} (= -X_{\text{max}})$	Field <sub>(mT)</sub> = -25mT	OUTPUT = 0
$\rightarrow X = 0\text{mm}$	Field <sub>(mT)</sub> = 0mT	OUTPUT = 511
$\rightarrow X = +1\text{mm} (= +X_{\text{max}})$	Field <sub>(mT)</sub> = +25mT	OUTPUT = 1023

Dynamic range of OUTPUT over  $\pm 1\text{mm}$ :  $\text{DELTA} = 1023 - 0 = 1023 \text{ LSB}$

Resolution =  $TD_{\text{max}} / \text{DELTA} = 2\text{mm} / 1024 = 1.95\mu\text{m/LSB}$

**Example 2:**

Using the same settings on the AS5510, the linear range of the magnet over the same displacement of  $\pm 1\text{mm}$  is now  $\pm 20\text{mT}$  instead of  $\pm 25\text{mT}$  due to a higher airgap or a weaker magnet. In that case the resolution of displacement vs. output value is lower.

Max. Travel Distance  $TD_{\text{max}} = \pm 1\text{mm}$  ( $X_{\text{max}} = 1\text{mm}$ ): unchanged

Sensitivity =  $\pm 25\text{mT}$  (Register 0Bh  $\leftarrow$  01h) : unchanged

$B_{\text{max}} = 20\text{mT}$	$\rightarrow X = -1\text{mm}$ ( $= -X_{\text{max}}$ )	$\text{Field}_{(\text{mT})} = -20\text{mT}$	OUTPUT = 102
	$\rightarrow X = 0\text{mm}$	$\text{Field}_{(\text{mT})} = 0\text{mT}$	OUTPUT = 511
	$\rightarrow X = +1\text{mm}$ ( $= +X_{\text{max}}$ )	$\text{Field}_{(\text{mT})} = +20\text{mT}$	OUTPUT = 920

Dynamic range of OUTPUT over  $\pm 1\text{mm}$ :  $\text{DELTA} = 920 - 102 = 818 \text{ LSB}$

Resolution =  $TD_{\text{max}} / \text{DELTA} = 2\text{mm} / 818 = \underline{2.44\mu\text{m/LSB}}$

In order to keep the best resolution of the system, it is recommended to adapt the sensitivity as close as the  $B_{\text{max}}$  of the magnet, with  $B_{\text{max}} < \text{Sensitivity}$  to avoid the saturation of the output value.

If a magnet holder is used, it must be made of a non-ferromagnetic material in order to keep the maximum magnetic field strength and maximum linearity. Materials as brass, copper, aluminium, stainless steel are the best choices to make this part.

## 5 Connecting the AS5510-AB

Two wires (I<sup>2</sup>C) only are required for the communication with the host MCU. Pull-up resistors are needed on both SCL and SDA line. The value depends on the length of the wires, and the amount of slaves on the same I<sup>2</sup>C line.

The power supply delivering between 2.7V ~ 3.6V is connected to the adapter board and the pull-up resistors.

A second AS5510 adapterboard (optional) can be connected on the same line. In that case, the I<sup>2</sup>C address must be changed by closing JP1 with a wire.

Figure 5:  
Typical connection to a host MCU (2nd adapterboard is optional)

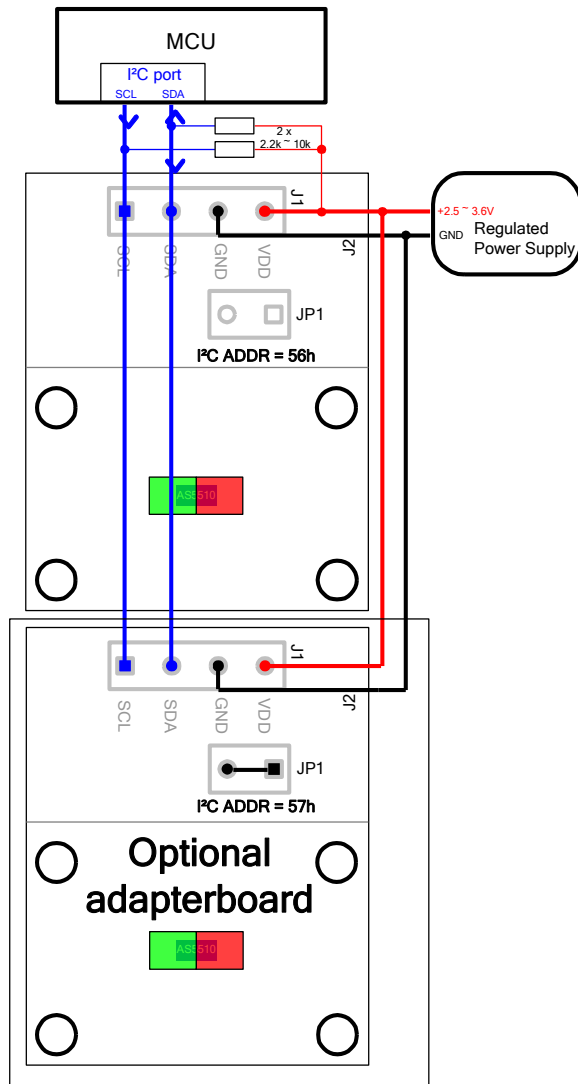

## 6 Software example

After powering up the system, a delay of >1.5ms must be performed before the first I2C Read/Write command with the AS5510.

The initialization after power up is optional. It consists of:

- Sensitivity configuration (Register 0Bh)
- Magnet polarity (Register 02h bit 1)
- Slow or Fast mode (Register 02h bit 3)
- Power Down mode (Register 02h bit 0)



Reading the magnetic field value is straight forward. The following source code reads the 10-bit magnetic field value, and converts to the magnetic field strength in mT (millitesla).

**Example:** Sensitivity configured to +-50mT range (97.66mT/LSB); Polarity = 0; default setting:

- D9..0 value = 0 means -50mT on the hall sensor.
- D9..0 value = 511 means 0mT on the hall sensor (no magnetic field, or no magnet).
- D9..0 value = 1023 means +50mT on the hall sensor.

```

Void main_loop(unsigned char Sensitivity_Mode)
{
    unsigned char Data1, Data2;
    short value;

    // 10-bit output value (0~1023)
    // The value 511 is the middle point @ 0mT
    float magnetic_field; // Value of the magnetic field in mT

    Data_LSB = I2C_Read8(I2C_ADDR, 0x00); // Read D7..0
    Data_MSB = I2C_Read8(I2C_ADDR, 0x01); // Read D9..8 + OCF + Parity

    value = ((Data_MSB & 0x03)<<8) + Data_LSB;

    switch (Sensitivity_Mode) // Sensitivity_Mode is the value stored in
        // register 0Bh
    {
        case 0: // Register [0Bh] <= 0 (+- 50mT range, 97.66uT/LSB)
            magnetic_field = (value - 511) * 0.09766;
            break;

        case 1: // Register [0Bh] <= 0 (+- 25mT range, 48.83uT/LSB)
            magnetic_field = (value - 511) * 0.04883;
            break;

        case 2: // Register [0Bh] <= 0 (+- 12.5mT range, 24.41uT/LSB)
            magnetic_field = (value - 511) * 0.02441;
            break;

        case 3: // Register [0Bh] <= 0 (+- 18.7mT range, 36.62uT/LSB)
            magnetic_field = (value - 511) * 0.03662;
            break;
    }

    printf("Decimal 10-bit value = %u \n", value);
    printf("Magnetic field value = %.3fmT \n", magnetic_field);
}

```

## 7 Schematic and Layout

Figure 6:  
AS5510-AB Schematic

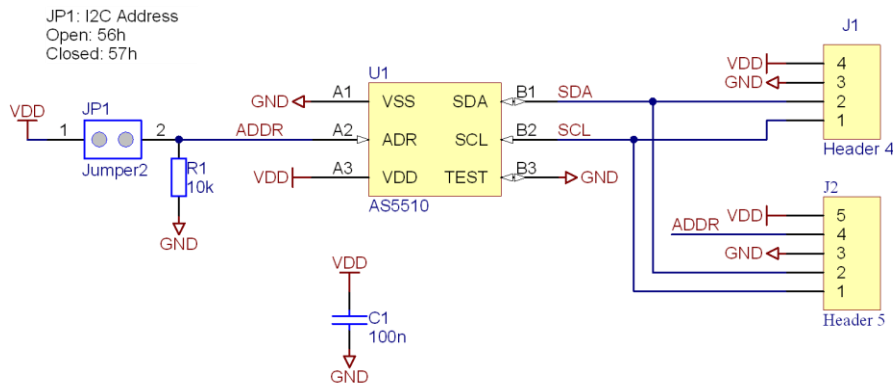
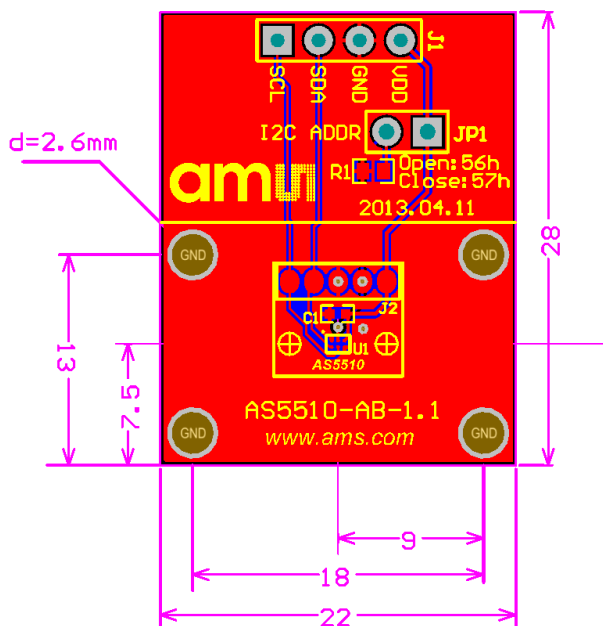

Figure 7:  
AS5510-AB Layout



## 8 Ordering Information

Table 2:

Ordering Information

Ordering Code	Description	comments
AS5510-WLCSP-AB	AS5510 Adapterboard	Adapterboard with sensor in wlcsp package